

OptiFeed BigBag (FPS16 / FPS16-E)

Fresh Powder Feed from the original BigBag container

The OptiFeed BigBag FPS16 and FPS16-E (Enamel) fresh powder system are designed for conveying the powder from large BigBag containers.

The OptiFeed PP06 Powder pump transports the powder from the original BigBag container to a distance of up to 25 meters.

An electropneumatic controller uses a sensor to monitor the powder flow and control the fresh powder supply.



OptiFeed BigBag FPS16-E



OptiFeed BigBag FPS16

Your global partner for high quality powder coating

Gema

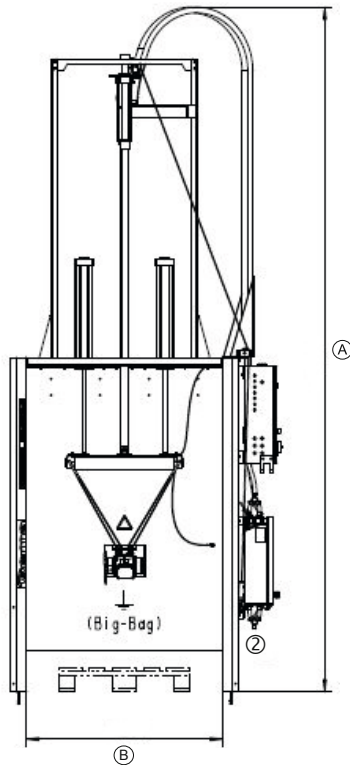

OptiFeed BigBag FPS16

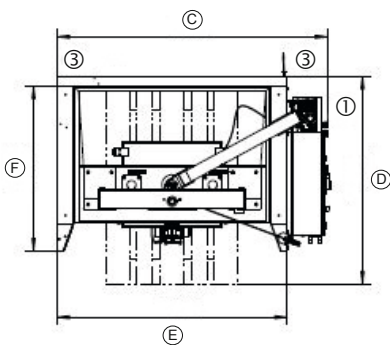

OptiFeed BigBag FPS16

	FPS16	FPS16-E
A	4201 mm	4898 mm
B	1200 mm	1340 mm
C	1648 mm	1737 mm
D	1260 mm	1200 mm
E	1400 mm	1500 mm
F	1000 mm	1100 mm

Gema Switzerland GmbH
 Mövenstrasse 17 | 9015 St.Gallen | Switzerland
 T +41 71 313 83 00 | F +41 71 313 83 83
 www.gemapowdercoating.com

Technical data OptiFeed BigBag (FPS16 / FPS16-E)

	FPS16	FPS16-E (Enamel)
Max. load:	500 kg	1250 kg
Container base area:	max. 800 x 1200 mm	max. 800 x 1200 mm
Compressed air:	max. 8 bar	max. 8 bar
Air consumption: (max. Nm ³ /h)	0.5 for lifting procedure 12 for each PP06 0.5 for fluidization	2.0 for lifting and lowering procedure 12 for each PP06 0.5 for suction tube
Power supply:	3 x 400 VAC / 24 VDC	3 x 400 VAC / 24 VDC
Frequency:	50 / 60 Hz	50 / 60 Hz
Performance:	140 VA	140 VA
Conveying performance:	<8 m = 5000 g/min 8-16 m = 4000 g/min 16-25 m = 3500 g/min	<8 m = 5000 g/min 8-16 m = 4000 g/min 16-25 m = 3500 g/min
Powder remaining quantity:	5% of the BigBag content	5% of the BigBag content
Connections:	① Female thread 1/2" ② Powder hose NW16 ③ Earthing	① Female thread 1/2" ② Powder hose NW16 ③ Earthing
Part No. Control on:	1 Pump 2 Pumps	1 Pump 2 Pumps
A- or B-Side	1 016 531 1 016 532	1 015 986 1 015 987
C-Side	1 016 534 1 016 535	1 015 991 1 015 992
Safety note:	Due to accident risk and depending on the placement of the fresh powder system, the safety barriers have to be placed in accordance to the local regulations.	

Configurations

FPS 16-1P:
 Equipment with 1 OptiFeed PP06 Powder pump

FPS 16-2P:
 Equipment with 2 OptiFeed PP06 Powder pumps

Control unit and pumps can be installed on the left or on the right side

Gema Switzerland reserves the right to make technical changes without notice!

